

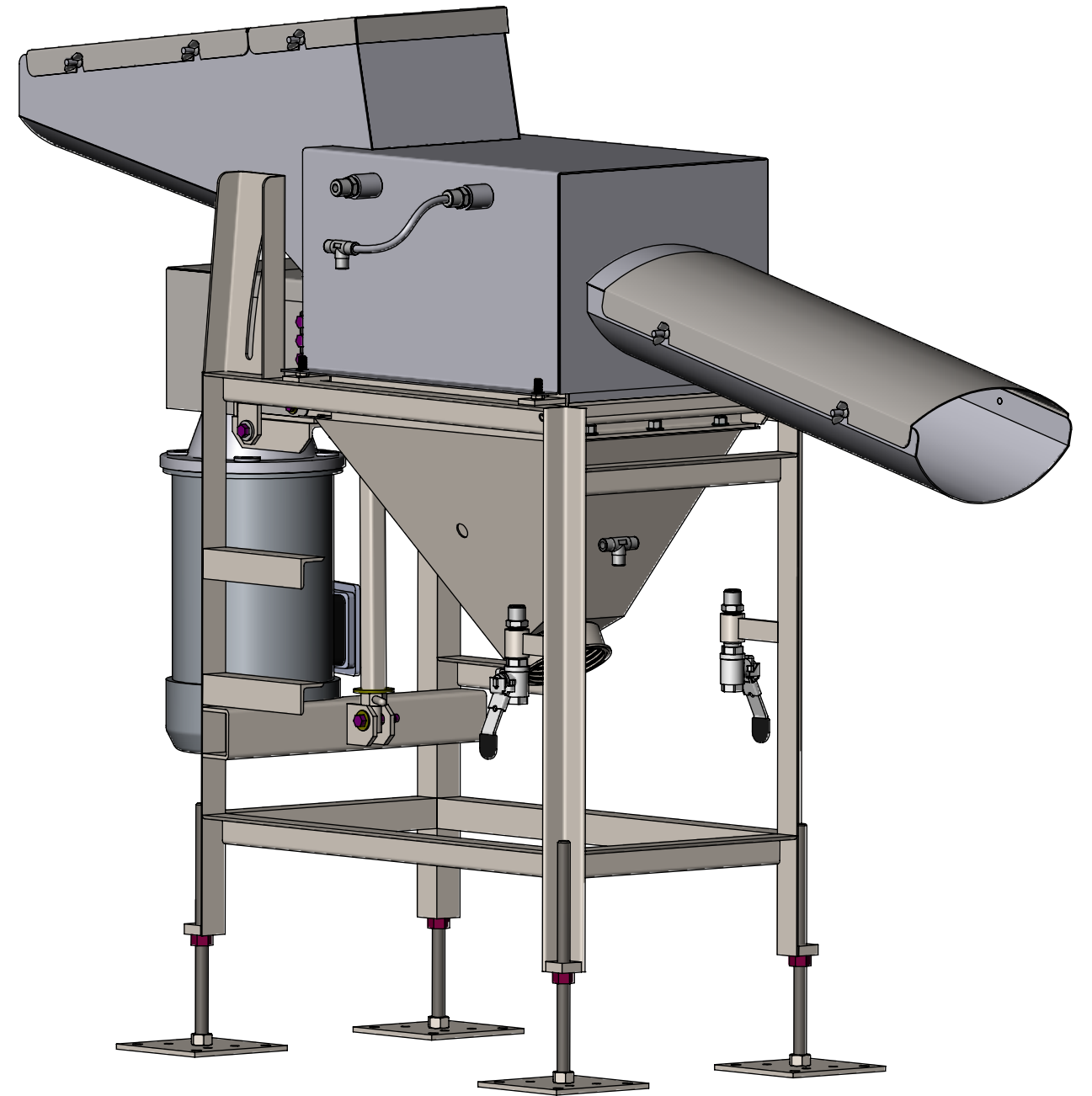

**BASE MODEL SKINNER**

- HANDED AS SHOWN IN APPROVAL DRAWING
- Standard frame as previous models; add ambidextrous box and valve mount
- #40 chain and sprockets
- 3HP motor with matching gearbox
- Gussets added to reinforce formed gearbox mount
- Bolt-on cover with nylock nuts
- Extended style infeed, per approval drawing
- Extended style outfeed, per approval drawing



NOTE:

JOB NO. <b>MPS-3218</b>			
QTY <b>1</b>		TITLE <b>BASE MODEL SKINNER EXTENDED INFEED/OUTFEED</b>	
SEE DETAILS MATERIAL		SIZE DRWN BY DWG NO	
SEE DETAILS FINISH		SCALE 1:8 WGT	
TOL: ANGLES ± 1° FRACTIONS ± 1/16 2 PLC DECIMAL ± .03 3 PLC DECIMAL ± .005		SHEET 1 OF 4	

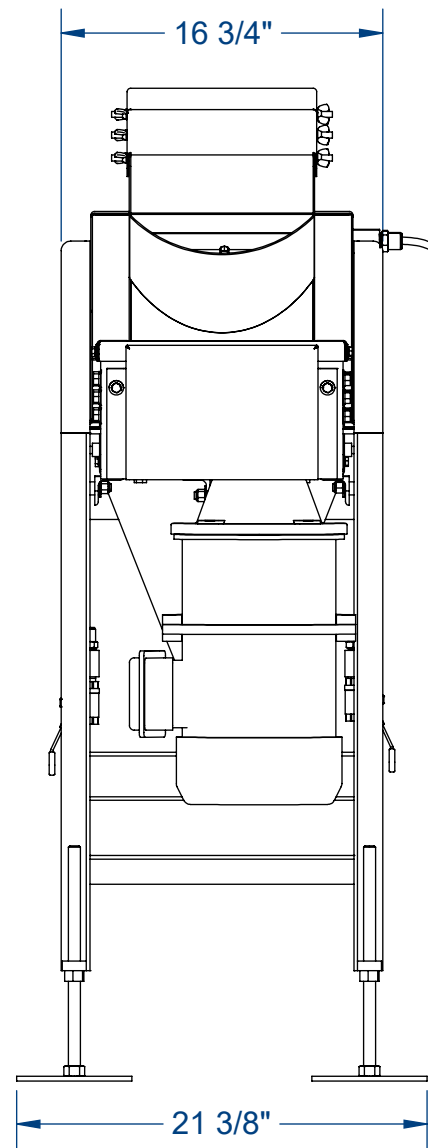

INLET VIEW

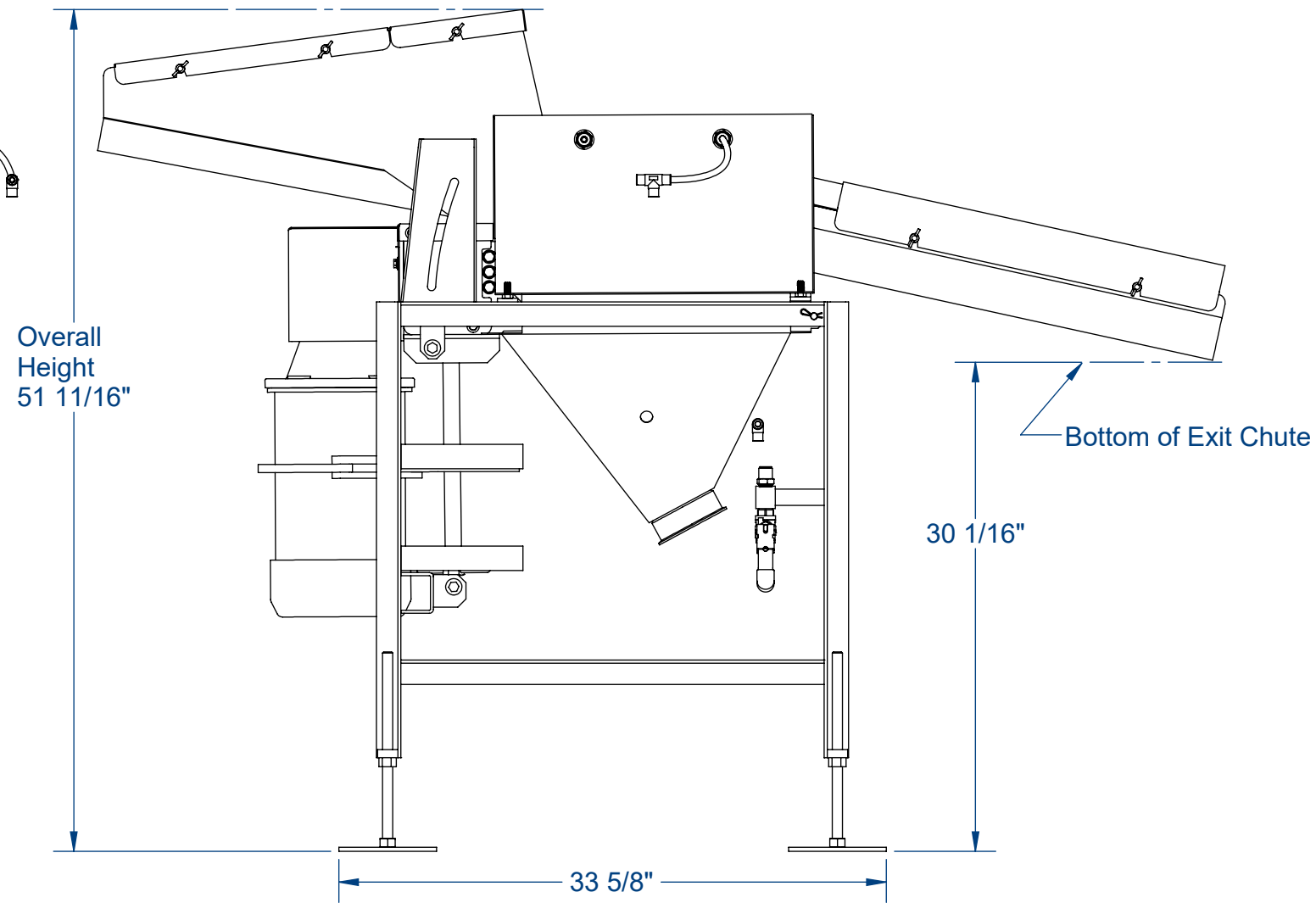

SIDE VIEW

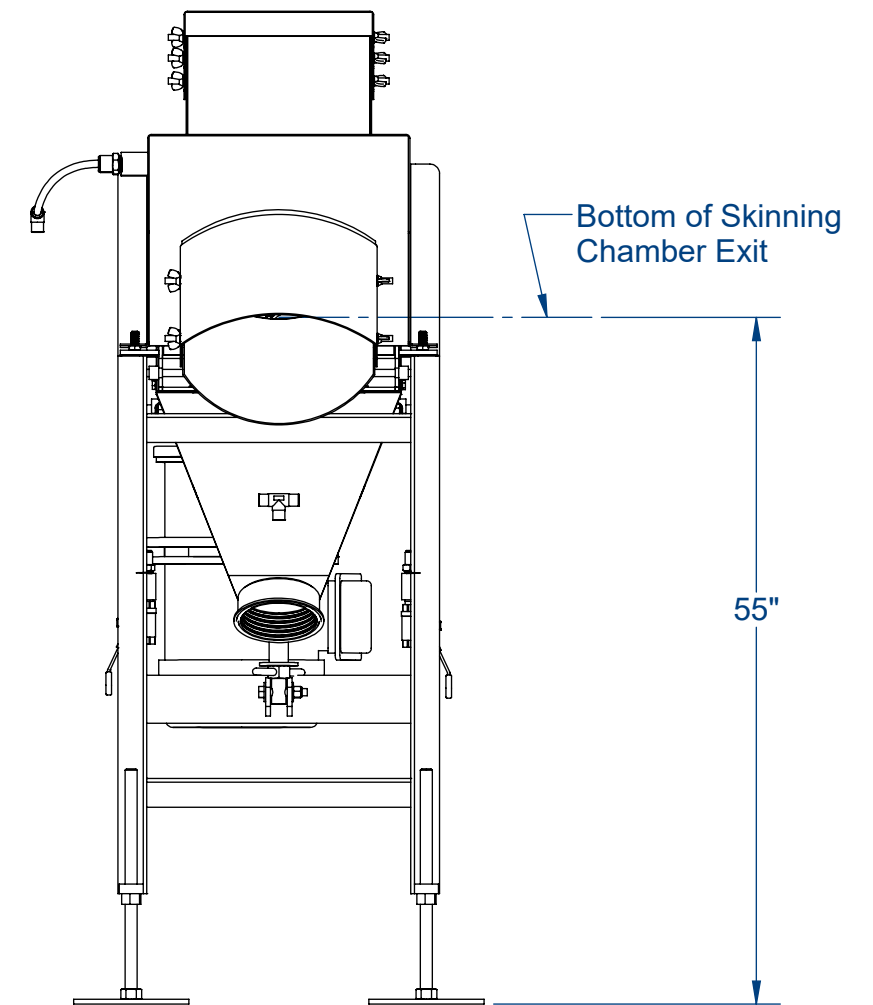

OUTLET VIEW

SKINNER SHOWN IN HORIZONTAL MODE

NOTE:

JOB NO.			
MPS-3218			
QTY		TITLE	
1		BASE MODEL SKINNER EXTENDED INFEED/OUTFEED	
MATERIAL		FINISH	
SEE DETAILS		SEE DETAILS	
SIZE	DRWN BY	DWG NO	REV
B			
SCALE	1:10	WGT	
SHEET 2 OF 4			

TOL: ANGLES ± 1°  
FRACTIONS ± 1/16  
2 PLC DECIMAL ± .03  
3 PLC DECIMAL ± .005

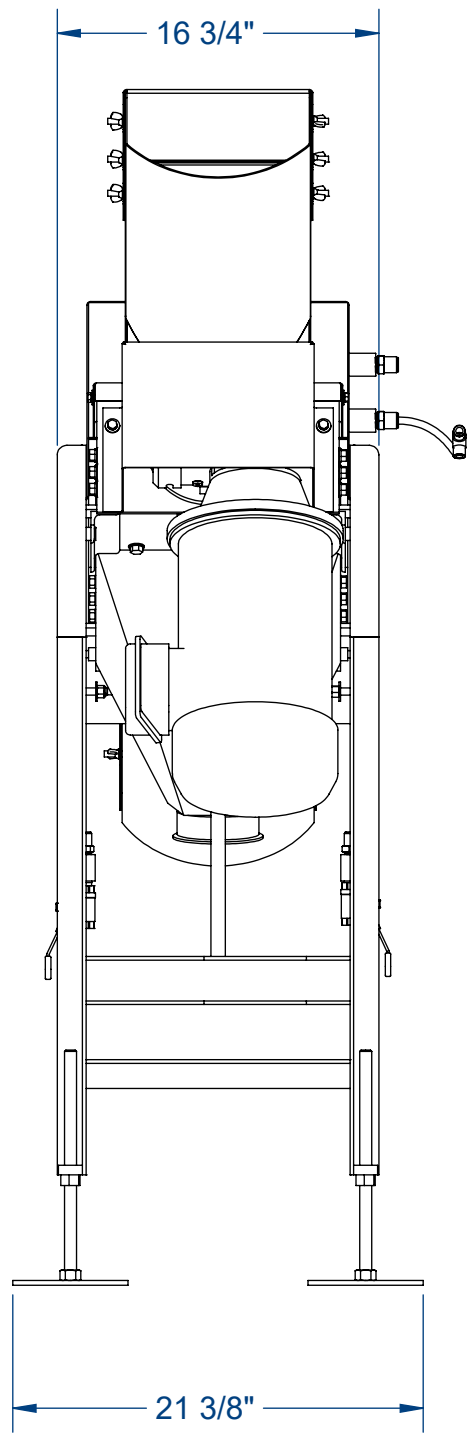

INLET VIEW

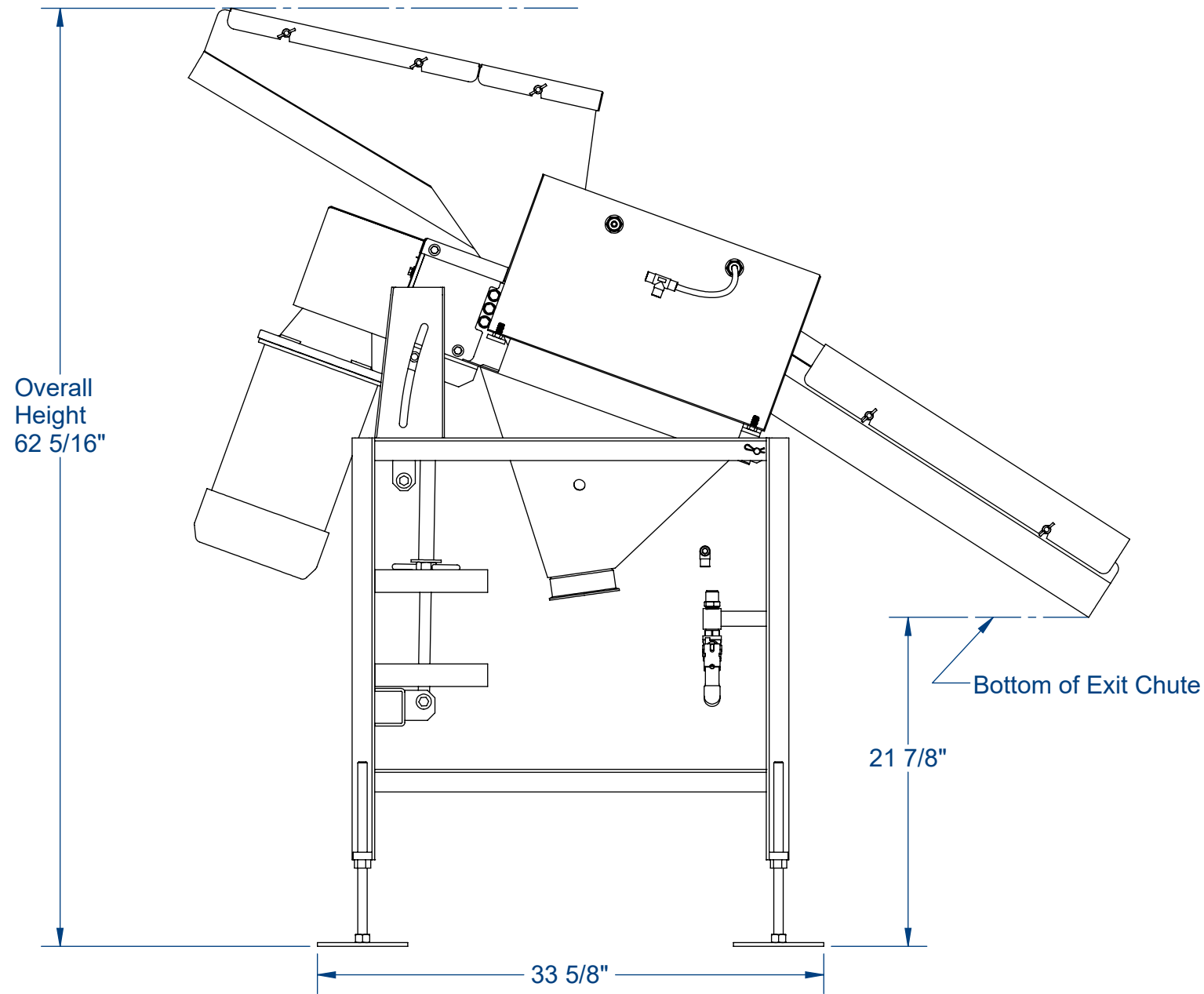

SIDE VIEW

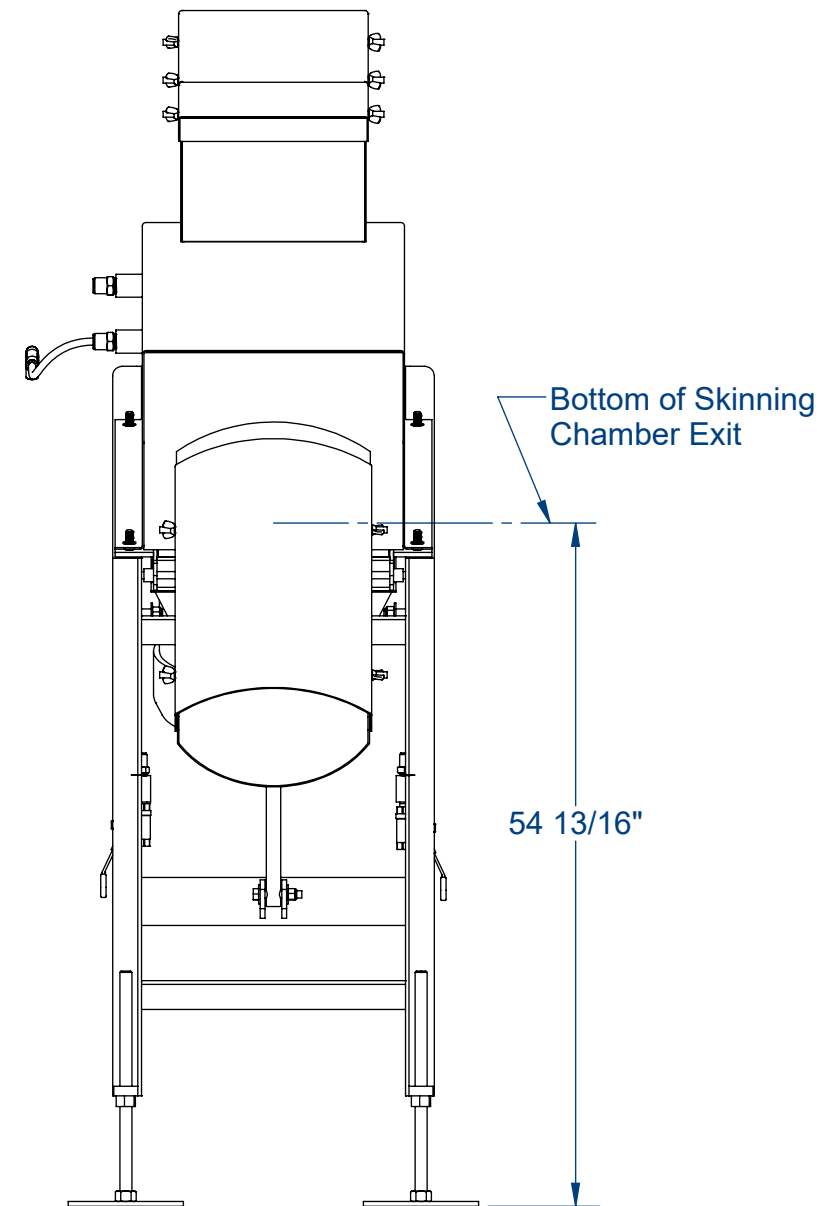

OUTLET VIEW

SKINNER SHOWN IN 20 DEG. INCLINE MODE

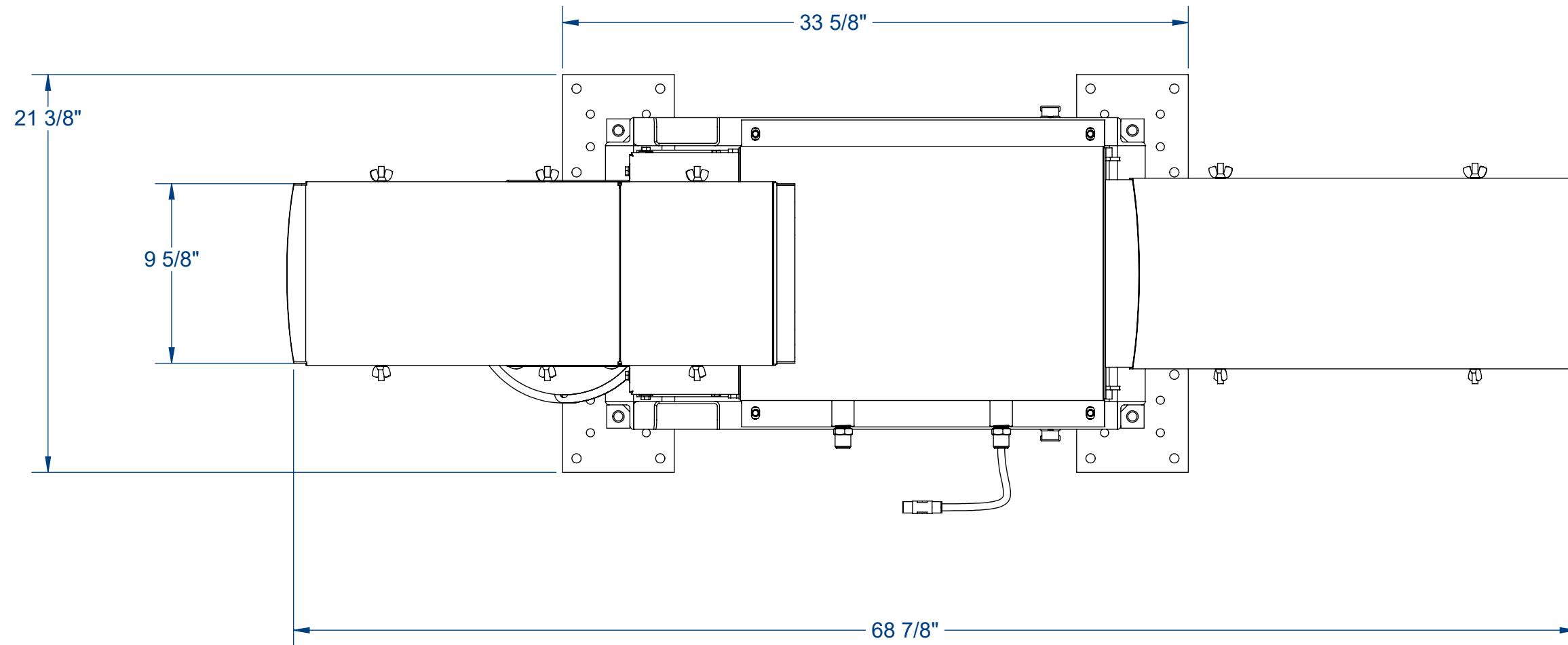

NOTE:

JOB NO.			
MPS-3218			
QTY		TITLE	
1		BASE MODEL SKINNER EXTENDED INFEED/OUTFEED	
MATERIAL		FINISH	
SEE DETAILS		SEE DETAILS	
SIZE	DRWN BY	DWG NO	REV
B			
SCALE	1:10	WGT	SHEET 3 OF 4
TOL:		ANGLES ± 1° FRACTIONS ± 1/16 2 PLC DECIMAL ± .03 3 PLC DECIMAL ± .005	



PLAN VIEW  
HORIZONTAL MODE

NOTE:

JOB NO. <b>MPS-3218</b>							
QTY <b>1</b>							
MATERIAL SEE DETAILS		TITLE <b>BASE MODEL SKINNER EXTENDED INFEED/OUTFEED</b>					
FINISH SEE DETAILS		SIZE <b>B</b>	DRWN BY	DWG NO	REV		
		TOL:	ANGLES ± 1° FRACTIONS ± 1/16 2 PLC DECIMAL ± .03 3 PLC DECIMAL ± .005		SCALE <b>1:7</b>	WGT	SHEET <b>4</b> OF <b>4</b>