

# Single LFT Bulking System

Model 3203



## ▼ DESCRIPTION

Product is fed via a conveyor or other material handling device to the bulker. Product falls through an open buffer hopper into a container on the weigh deck. Once a pre-programmed target weight is achieved, the buffer hopper closes and the product collects in the buffer hopper until the infeed stop delay is surpassed, or the system is re-set by the operator.

The bulker operator can “make weight,” if needed, to achieve the final target weight. After weight has been met, the operator pushes the “print” button and applies the container label, then moves the full container to the next processing step. The operator will next place an empty container on the weigh deck and press the “auto start” button to begin the next fill cycle. The operation continues until parameter changes are required, a process break occurs, or the end of the shift is reached.

## Advantages & Benefits

- High return on investment
- Reduced product “giveaway”
- Labor savings – most applications at least one operator per shift
- Higher volumes achieved than with manual labor alone
- Real-time process reporting
- Multiple delivery options:
  - Specialty boxes
  - 30 / 60 lb. boxes
  - Export size containers
- Maintenance-friendly ... easy accessibility for service

## Features

- Revolutionary *Gainco Infinity® Plus* programmable controller
- Suitable for all meat species and further-processed products
- Smaller footprint
- AMI sanitary design
- RF / WiFi connectivity
- Ethernet
- Fully integrates with optional *DataMan™* data management system

## Technical Specifications

<b>Capacity</b>	70 lbs (Buffer Hopper) 200 lbs (Weigh Deck)
<b>Throughput</b>	up to 6 cycles/min
<b>Accuracy</b>	0.01% Full Scale
<b>Controller Type</b>	Gainco Infiniti® LCD
<b>No. of Controllers</b>	1
<b>Installed Power</b>	120v x 1
<b>Air Connection</b>	(3/8" hose or 1/2" NPT)
<b>Air Consumption</b>	80 PSI / 5 CFM
<b>Water Connections</b>	N/A
<b>Water Consumption</b>	N/A
<b>RF Option</b>	Yes
<b>WiFi Option</b>	Yes
<b>Data Management</b>	Yes, Optional
<b>Report Generation</b>	Yes, Optional
<b>Label Printer Option</b>	Yes, Optional
<b>Width</b>	5'1"
<b>Depth or Length</b>	3'2"
<b>Height (Standard)</b>	6'2" (top of hopper) 3'2" (top of weigh deck)
<b>Height (w/Diverter)</b>	N/A

## AccuFill™ Single LFT Bulking System – Model 3203

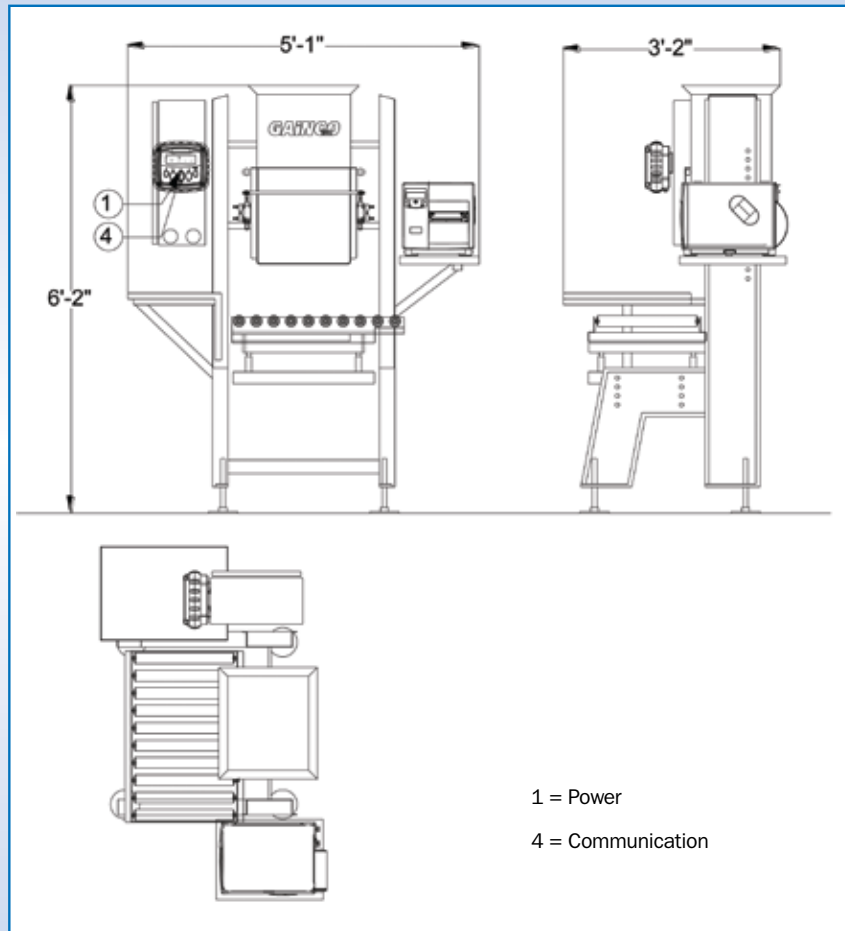

1 = Power  
4 = Communication

## Options & Accessories

A variety of options and accessories are available to meet special requirements:

- GSE 661 or GSE 665 controller
- UL controls
- 20# or 40# capacity hoppers
- Dimpled stainless steel or electro-plate hoppers in place of standard smooth stainless steel
- Channel or square tubing frame construction
- Ethernet, WiFi or Bluetooth® connectivity
- Adjustable container platforms with stainless steel roller ball bearing top ... or in smooth stainless steel
- Air clutch control valve, variable frequency drive and dry contact relay line controls
- Labeling system interface
- Datamax® or Zebra® printers
- Mobility kit
- Infeed conveyors

## Operating Parameters

**Single bulker:** Up to 6 cycles/min

**Throughput:** 420 pounds per minute

**Accuracy:** +/- 0.1% of the true product weight, 99.5% of the time

**Controller type:** Gainco Infiniti® Plus

**For additional information on equipment specs, contact your Gainco technical sales representative or call toll-free 800-869-7410.**



1635 Oakbrook Drive, Gainesville, GA 30507 USA  
Tel. 770-534-0703 | Toll-Free: 877-869-7410  
FAX: 770-534-4591 | E-mail: info@gainco.com

[www.gainco.com](http://www.gainco.com)

Member:



A subsidiary of:  
**BETTCHEr**  
Industries, Inc.

AccuFill, DataMan, Gainco Infiniti and the Gainco design are trademarks of Gainco, Inc. The Bettcher design is a registered trademark of Bettcher Industries, Inc. Datamax is a registered trademark of Datamax Corporation. Zebra is a registered trademark of Zebra Technologies Corporation. Bluetooth is a registered trademark of Bluetooth SIG, Inc. ©2009 Gainco, Inc. All rights reserved.