

ALESHA

- Special design finger to fit in a Berry paw picking machine.
- Available in all hardness.

A 34mm x 37mm / 1.34" x 1.46"	K 3mm / 0.12"
B 22mm x 25mm / 0.89" x 0.98"	L 149mm / 5.87"
C 29mm / 1.14"	M 94mm / 3.7"
D 24.5mm / 0.96"	N 135mm / 5.32"



CT400

- Flat, strong finger with double-sided ribbing, long-lasting, highly efficient, designed for difficult jobs such as turkeys and ducks.
- Flat shape allows excellent contact with the skin surface, providing much closer picking.
- Finger's flexibility prevents barking.
- Ideal for turkeys.

A 35mm x 38mm / 1.38" x 1.5"	K 3mm / 0.12"
B 25mm x 22mm / 0.98" x 0.87"	L 148mm / 5.83"
C 28mm / 1.1"	M 89mm / 3.5"
D 34mm / 1.34"	N 133mm / 5.24"



DEBONING DISK

- Designed especially for Systemate de-boning systems and available in three core diameter sizes:
- DBMM 11mm core
- DBMM 12mm core
- DBMM 14mm core
- De-boning disks are manufactured to nominal hardness factor of 65 (hard).
- Variations to standard core sizes are available as required.



QUINN

- A round finger with strong grip in the disc.
- Designed for use in the lid of any paw picker.
- Available in all hardness.

A 27mm / 1.06"	K 2.3mm / 0.09"
B 20mm / 0.79"	L 110mm / 4.33"
C 24mm / 0.94"	M 55mm / 2.17"
D 17.5mm / 0.69"	N 96mm / 3.78"

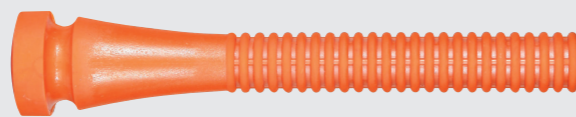

CT103

- For broilers, the soft version of the CT103 is recommended.
- Designed for Barker RP3000, Lincomatic and other counter rotating machines.
- Flexibility makes this finger suitable for bench or pedestal mounted drum pluckers.
- Ideal for duck finishing.

A 27mm / 1.06"	K 7mm / 0.28"
B 19mm / 0.75"	L 146mm / 5.75"
C 23mm / 0.91"	M 90mm / 3.54"
D 15mm / 0.59"	N 130mm / 5.12"

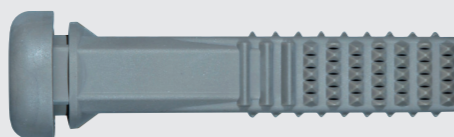

CT620

- Unique design for more aggressive paw picking.
- Highly suitable for difficult jobs.
- Delivers excellent picking performance.
- Available in all hardness.

A 35mm / 1.38"	K 4mm / 0.16"
B 26mm x 21mm / 1.02" x 0.83"	L 123mm / 4.84"
C 28mm / 1.1"	M 61mm / 2.4"
D 24mm / 0.94"	N 107mm / 4.2"

Colour chart for rubber fingers

HARDNESS	COLOUR CODE	NOMINAL SHORE A HARDNESS
SOFT	BLUE	52
MEDIUM	BROWN	58
HARD	TAN	63
VERY HARD	GREEN	68

Colour chart for (i) fingers

HARDNESS	COLOUR CODE	NOMINAL SHORE A HARDNESS
SOFT	DARK BLUE	52 (i)
MEDIUM	DARK BROWN	58 (i)
HARD	GREY	63 (i)

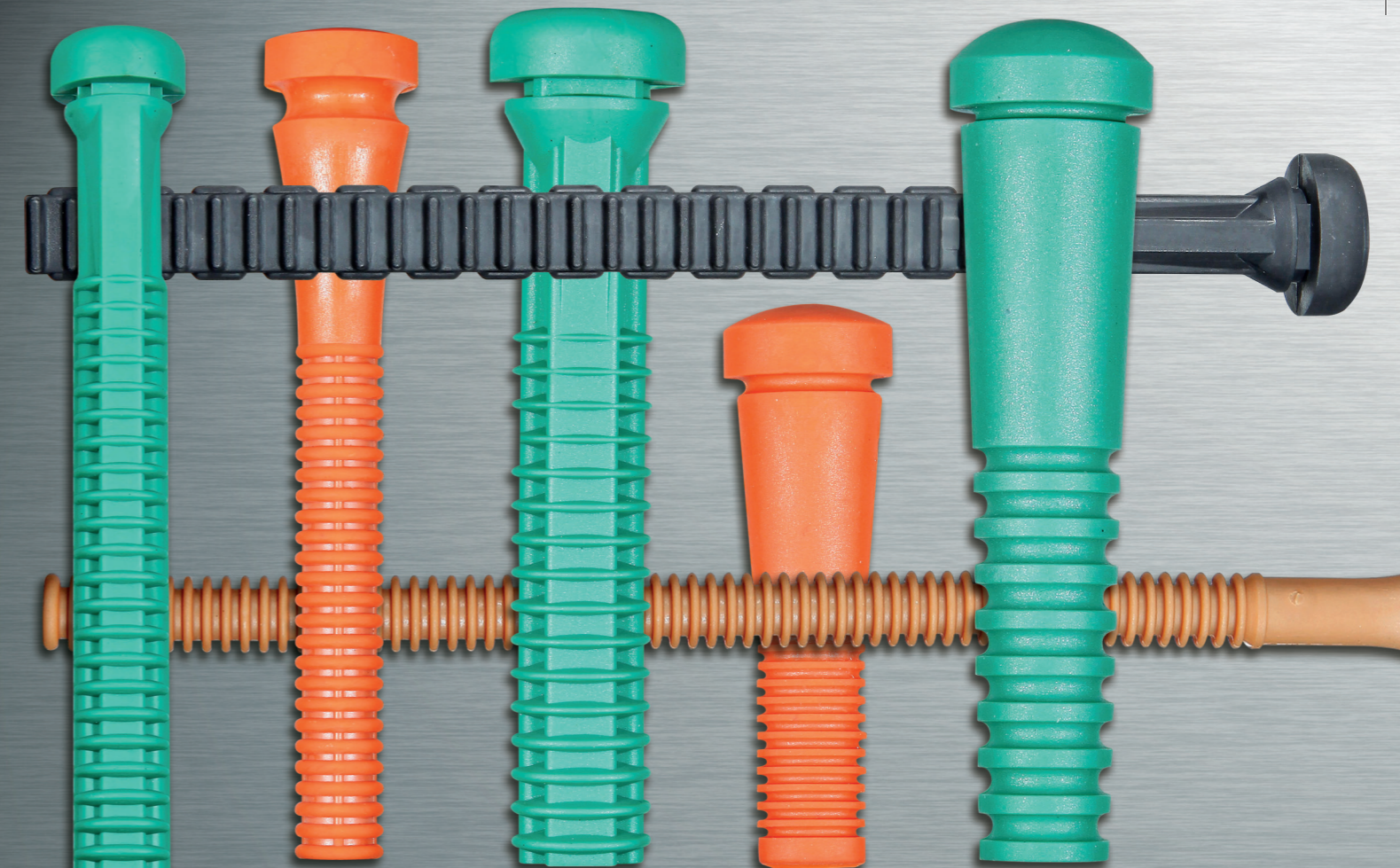

C-TECH



C-TECH

C-TECH RUBBER (M) SDN BHD

16-6-1, Block F, Jalan Semarak Api 3, Diamond Square,
Off Jalan Gombak, 53000 Kuala Lumpur, Malaysia
Tel: +603 4024 6655 Fax: +603 4024 1818 Email: sales@c-tech.com.my

DURABLE • ECONOMICAL • EFFICIENT • QUALITY

C-Tech quality is the result of manufacturing to rigidly high standards of production control, using technically specified rubber. Malaysia has long been recognised as an international leader in rubber technology and production.

C-Tech standards are based on three key areas – quality of ingredients; techniques of rubber compound mixing; and the moulding process.

The C-Tech formula used for these three functions are proprietary. They are not for sale or use by third parties and are the result of extensive tests in laboratories and field environments.

C-Tech performance has been consistently proven in use by all the most popular defeathering machines in the world over: reduction in breakage, premature

wear, and 'aging' explain why C-Tech plucking fingers have become a world market leader.

C-Tech is competitively priced, and in combination with its renowned performance, will further reduce your overall production cost without compromising efficiency and quality.

Call us today at +603 4024 6655 for a no-obligation quote.

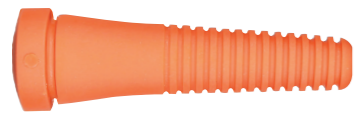
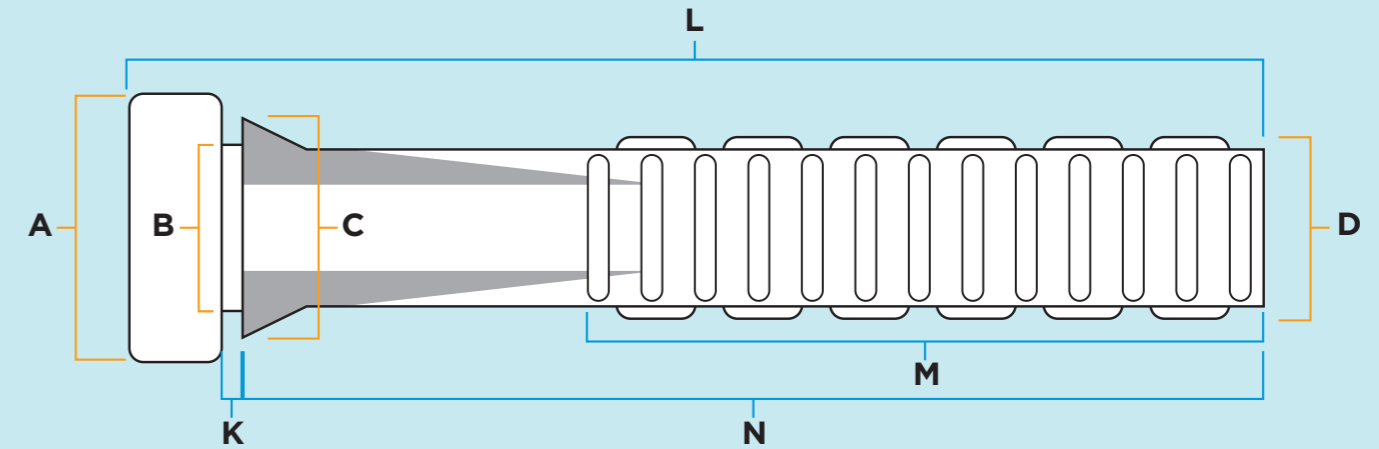

DS

- Specially designed round finger with excellent picking performance.
- Fits Stork, Meyn, Linco, Cantrell and New Johnson.
- Available in all hardness.

A	27mm / 1.06"	K	2mm / 0.08"
B	20.5mm / 0.81"	L	90mm / 3.54"
C	23.5mm / 0.93"	M	51mm / 2"
D	13.5mm / 0.53"	N	81.5mm / 3.2"

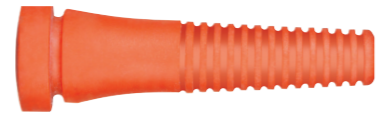

JS

- These round fingers deliver gentle contact without skin damage.
- Fits Johnson Dura, Impianti, and paw pickers.
- Available in all hardness.

A	30mm / 1.18"	K	3mm / 0.12"
B	21mm / 0.83"	L	96mm / 3.78"
C	25mm / 0.98"	M	53mm / 2.09"
D	15mm / 0.59"	N	84mm / 3.3"



CT200

- A long-lasting, durable oval finger that allows gentle contact and excellent picking performance without barking.
- Design for Stork (S071), Gordon-Johnson (T1), Meyn and rotary drum pluckers.

A	29mm / 1.14"	K	3mm / 0.12"
B	21mm / 0.83"	L	95mm / 3.74"
C	24.5mm / 0.96"	M	42mm / 1.66"
D	19mm / 0.75"	N	80mm / 3.15"



ADAM

- Specially designed by C-Tech, this unique oval finger is longer in length and with stepped ribbing which allows for excellent picking.
- Designed for Stork, Meyn, Linco, Cantrell and New Johnson.
- Available in all hardness.

A	29.5mm / 1.61"	K	3mm / 0.12"
B	22mm / 0.87"	L	108mm / 4.25"
C	24.5mm / 0.96"	M	57.5mm / 2.26"
D	14.8mm / 0.58"	N	95.5mm / 3.76"

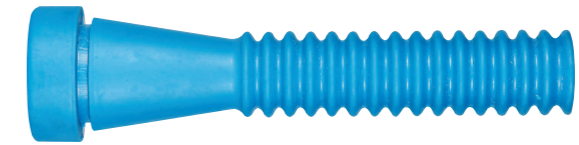

CT600

- A round hollow finger that suits Bayle & Orty counter rotating machines and is highly suitable for broilers, ducks, turkeys and other large game birds.
- Being a hollow finger, CT600's flexibility provides superbly gentle contact eliminating barking and providing excellent picking quality and durability.
- CT600 is ideal for de-waxing ducks in either multi-bank or counter rotating machines.
- Available in all hardness.

A	36mm / 1.42"
B	26mm / 1.02"
C	30mm / 1.81"
D	22.5mm / 0.89"
K	3.15mm / 0.12"
L	143mm / 5.63"
M	88mm / 3.46"
N	127mm / 5"

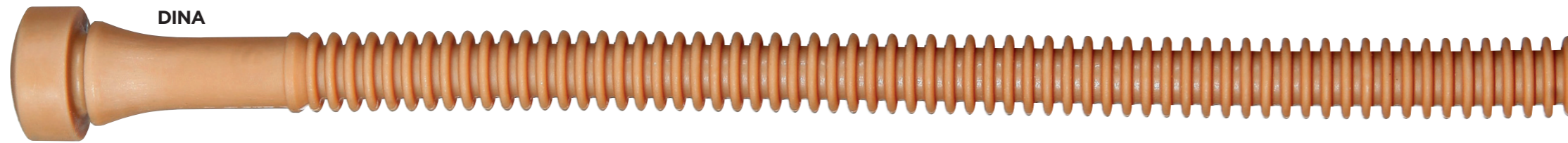

DINA

- A versatile finger with a round solid construction for turkey pickers.
- Fits Barker Straddle.
- Available in various hardness.

A	25.5mm / 1"	K	2.5mm / 0.1"
B	15mm / 0.59"	L	29.5mm / 1.16"
C	20mm / 0.79"	M	240mm / 9.45"
D	15mm / 0.59"	N	279mm / 10.98"



CT140

- A solid round finger with excellent grip at the disc makes it ideal for difficult turkey picking.
- Designed for Stork pickers.
- Available in all hardness.

A	37mm x 34mm / 1.46" x 1.34"	K	3.5mm / 0.14"
B	26mm x 21mm / 1.02" x 0.83"	L	141mm / 5.55"
C	29mm / 1.14"	M	85mm / 3.35"
D	19mm / 0.75"	N	127mm / 5"



GA

- Long, flat and with ribbing on both sides.
- Used for turkey, bigger birds and finisher pluckers.
- Fits all hock pickers.
- Available in all hardness.

A	33mm x 35mm / 1.3" x 1.38"	K	3mm / 0.12"
B	20mm x 18mm / 0.79" x 0.71"	L	266mm / 10.47"
C	23mm / 0.91"	M	200mm / 7.87"
D	19mm / 0.75"	N	252mm / 9.92"

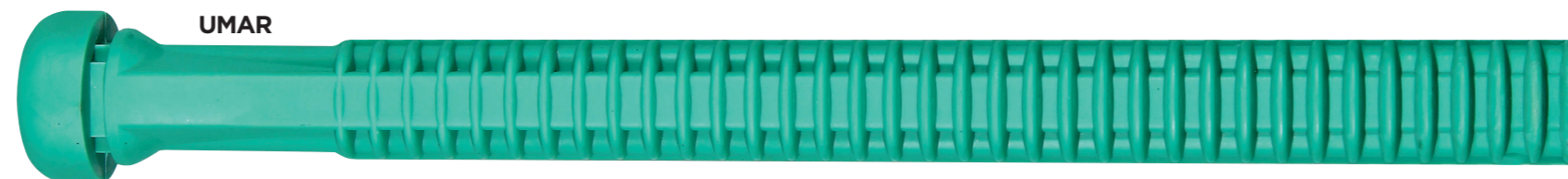

UMAR

- Long, flat finger with ribbing on one side.
- Fits Barker Straddle and Gordon Johnson.
- Available in all hardness.

A	30mm / 1.18"	K	3mm / 0.12"
B	19mm / 0.75"	L	265mm / 10.43"
C	24mm / 0.94"	M	210mm / 8.27"
D	20mm / 0.79"	N	250mm / 9.84"

C-TECH

C-TECH RUBBER (M) SDN BHD

16-6-1, Block F, Jalan Semarak Api 3, Diamond Square,
Off Jalan Gombak, 53000 Kuala Lumpur, Malaysia
Tel: +603 4024 6655 Fax: +603 4024 1818 Email: sales@c-tech.com.my